

# OPERATING INSTRUCTIONS FORCED AIR PROPANE CONSTRUCTION HEATERS

## Models

**25,000 - 45,000 BTU/hr    30,000 BTU/hr    40,000 BTU/hr**  
**50,000 - 85,000 BTU/hr    75,000 - 125,000 BTU/hr**

HEATER SPECIFICATION						
Type of Gas	For Use with Propane Only					
Gas Supply Pressure to Regulator	Max: Bottle Pressure Min: 5 psig					
Regulator out	28" W.C. (11" W.C. for 30,000 BTU/hr and 40,000 BTU/hr)					
Electrical Input	115V, 60 Hz 1 $\phi$ , 3a					
Minimum Operating Voltage	100V					
Ignition	Direct Spark (Manually operated for 30,000 BTU/hr heaters)					
Primary Flame Control	Thermocouple Operated Gas Valve					
High Temperature Control	240°F					
Min. Ambient Temp. Rating	0°F					
Rating:	Adjustable			Adjustable		Adjustable
	25,000-45,000 BTU/hr	30,000 BTU/hr	40,000 BTU/hr	50,000-85,000 BTU/hr	75,000-125,000 BTU/hr	
Fuel Consumption:	1.2 - 2.1 #/hr	1.4 #/hr	1.8 #/hr	2.3 - 3.9 #/hr	3.5 - 5.8 #/hr	
Fuel Orifice:	0.0180" x 18 holes	.073" dia.	.55mm x 18 holes	0.024" x 18 holes	.75mm x 18 holes	
Heated Air Output:						
CFM:	250	140	250	350	350	
Average Air Temp Rise:	170°F	250°F	160°F	200°F	400°F	



**YOUR SAFETY IS IMPORTANT TO YOU AND TO OTHERS,  
SO PLEASE READ THESE INSTRUCTIONS BEFORE YOU  
OPERATE THIS HEATER.**



### GENERAL HAZARD WARNING:

FAILURE TO COMPLY WITH THE PRECAUTIONS AND INSTRUCTIONS PROVIDED WITH THIS HEATER, CAN RESULT IN DEATH, SERIOUS BODILY INJURY AND PROPERTY LOSS OR DAMAGE FROM HAZARDS OF FIRE, EXPLOSION, BURN, ASPHYXIATION, CARBON MONOXIDE POISONING, AND/OR ELECTRICAL SHOCK.

ONLY PERSONS WHO CAN UNDERSTAND AND FOLLOW THE INSTRUCTIONS SHOULD USE OR SERVICE THIS HEATER.

IF YOU NEED ASSISTANCE OR HEATER INFORMATION SUCH AS AN INSTRUCTIONS MANUAL, LABELS, ETC. CONTACT THE MANUFACTURER.



**WARNING: FIRE, BURN, INHALATION, AND EXPLOSION HAZARD. KEEP SOLID COMBUSTIBLES, SUCH AS BUILDING MATERIALS, PAPER OR CARDBOARD, A SAFE DISTANCE AWAY FROM THE HEATER AS RECOMMENDED BY THE INSTRUCTIONS NEVER USE THE HEATER IN SPACES WHICH DO OR MAY CONTAIN VOLATILE OR AIRBORNE COMBUSTIBLES, OR PRODUCTS SUCH AS GASOLINE, SOLVENTS, PAINT THINNER, DUST PARTICLES OR UNKNOWN CHEMICALS.**

**SCHEU PRODUCTS COMPANY, INCORPORATED**  
**MAIL: P.O. BOX 250, UPLAND, CA 91785**  
**PLANT: 8855 BAKER AVE., RANCHO CUCAMONGA, CA 91730**  
**TELEPHONE: 909-981-5343**



ANSI Z83.7b-1993/CGA 2.14-1972

P/N 7385J  
September 2000

## OPERATING PRECAUTIONS

This is a propane, direct-fired, forced air heater. It's intended use is primarily temporary heating of buildings under construction, alteration or repair.

**WARNING**  
**NOT FOR HOME OR RECREATIONAL VEHICLE USE**

Propane is heavier than air. If propane leaks from a connection or fitting, it sinks to the floor, collecting there with the surrounding air, forming a potentially explosive mixture. Obviously, propane leaks should be avoided, so set up the propane supply with utmost care. Leak check new connections or reconnections with a soap and water solution and follow all connection instructions herein. Also, ask your propane dealer for advice on the propane application and supply installation and ask him to check it if there are any questions.

Direct-Fired means that all of the combustion products enter the heated space. Even though this heater operates very close to 100 percent combustion efficiency, it still produces small amounts of carbon monoxide. Carbon monoxide (called CO) is toxic. We can tolerate small amounts but not a lot. CO can build up in a heated space and failure to provide adequate ventilation could result in death. The symptoms of inadequate ventilation are:

- headache
- dizziness
- burning eyes and nose
- nausea
- dry mouth or sore throat

So, be sure to follow advice about ventilation in these operating instructions.

Forced Air means that a blower or fan pushes the air through the heater. Proper combustion depends upon this air flow; therefore, the heater must not be revised, modified or operated with parts removed or missing. Likewise, safety systems must not be circumvented or modified in order to operate the heater.

**When the heater is to be operated in the presence of other people the user is responsible for properly acquainting those present with the safety precautions and instructions, and of the hazards involved.**

## SAFETY PRECAUTIONS

1. Check the heater thoroughly for damage. DO NOT operate a damaged heater.
2. DO NOT modify the heater or operate a heater which has been modified from its original condition.
3. Use only propane gas.
4. Use only VAPOR WITHDRAWAL propane supply. If there is any question about vapor withdrawal, ask your propane dealer.
5. Mount the propane cylinders vertically (shutoff valve up). Secure them from falling or being knocked over and protect them from damage.
6. Locate propane containers at least 7 ft. from the heater and **do not** direct exhaust toward containers.
7. Use only the hose and regulator assembly provided with the heater. Inspect hose assembly before each use of the heater. If there is excessive abrasion or wear, or hose is cut, replace with hose assembly listed on parts list before using heater.
8. For indoor use only. Area must be well ventilated. Provide minimum openings of 1 sq. ft. near the floor and 1 sq. ft. near the ceiling (also see "Operating Precautions").
9. If at any time gas odor is detected, IMMEDIATELY DISCONTINUE operation until the source of gas has been located and corrected.
10. Install the heater such that it is not directly exposed to water spray, rain and/or dripping water.
11. Maintain minimum clearance from normal combustible material (like paper) as follows: floor-0 ft.; outlet-6 ft.; sides-2 ft.; top-3 ft. Locate 10 ft. from canvas or plastic tarpaulins or similar coverings and secure them to prevent flapping or movement due to wind action.
12. Operate only on a stable, level surface.
13. Do not use with ductwork. Do not restrict inlet or exit.
14. Use only the electrical power specified. The electrical connection and grounding must comply with National Electrical Code - ANSI/NFPA 70.
15. Use only a properly grounded 3-prong receptacle or extension cord.
16. Do not move, handle or service while hot or burning.
17. Use only in accordance with local codes or, in the absence of local codes, with the Standard for the Storage and Handling of Liquefied Petroleum Gases ANSI/NFPA 58-1998.

**RETAIN THESE INSTRUCTIONS FOR FUTURE REFERENCE.**

## PROPANE FUEL PRECAUTIONS

### WARNING:

Local codes for installation of propane systems may vary considerably. Therefore, ask your local propane supplier for advice on propane system installation in your particular area. In the absence of local codes, install in accordance with American National Standards Institute (ANSI)/National Fire Protection Association (NFPA) publication Standard for the Storage and Handling of Liquefied Petroleum Gases ANSI/NFPA 58-1998. Your supplier, fire marshal or library should have a copy.

The propane supply system must be arranged for vapor withdrawal. Propane cylinders must be secured in the upright position to keep them from falling or being knocked over.

During use, liquid propane in a container vaporizes. As it vaporizes, the propane cools itself. If this cooling process continues long enough and proceeds fast enough, the propane temperature and pressure will fall so low that heater operation may be improper or even impossible even though plenty of propane remains in the container. Often frost forms on the outside of the propane container as a warning of excessive refrigeration.

Recommendations to reduce the ill effects of refrigeration are:

- \* Provide considerably more propane than you plan to consume. As a rule of thumb, provide twice as much.
- \* Fill containers frequently, especially in cold weather. Never allow propane to fall below one-third of container capacity.
- \* If possible, keep containers in a warm area. Under no circumstances should the heater exhaust be directed toward the propane container.
- \* Watch for frost formation on the container. If it occurs, discontinue use of the heater and refill the container.

### NOTE:

See page 4 for size and capacity of propane cylinders required.

Cubic feet of space to be heated	BTU'S PER HOUR REQUIRED			
	Temperature Rise Required (°F)*			
	20°	30°	40°	50°
5,000	14,000	20,000	27,999	34,000
7,000	19,000	28,000	38,000	47,000
10,000	27,000	40,000	54,000	67,000
15,000	40,000	60,000	80,000	100,000
20,000	54,000	80,000	107,000	133,000
30,000	80,000	120,000	160,000	200,000
50,000	133,000	200,000	266,000	333,000

## OPERATING INSTRUCTIONS

### PREPARING FOR OPERATION

1. Check the heater for possible shipping damage. If any is found, *immediately* notify your dealer.
2. Follow all of the "Precautions" on pages 2 & 3.
3. Connect the POL fitting of hose and regulator assembly to the propane cylinder by rotating the POL nut counterclockwise into the propane cylinder's valve outlet and securely tighten with a wrench.
4. Connect the hose to the heater by rotating the hose fitting clockwise.
5. Securely tighten all gas connections.
6. Open the cylinder's gas valve and check all gas connections with a soap and water solution. **DO NOT USE A FLAME.**
7. Connect power cord to well-grounded 115V, 60 Hz, 1∅ source of power.
8. When using an extension cord, make certain that it is a 3-wire (grounded) cord of proper wire size.

### START

1. Slowly open the main valve at propane cylinder.
2. Depress the fuel valve button to light the 40,000, 45,000, 85,000 and 125,000 BTU/hr models. On the 30,000 BTU/hr push the ignition button until the heater lights.
3. After the heater lights keep the gas valve button depressed for 15 seconds then release and the heater will continue to operate.
4. Adjust burn rate with ball valve (25-45,000, 50-85,000 and 75,000-125,000 BTU/hr only).

### STOP

1. Securely close valve on the propane cylinder.
2. Continue to operate heater until all fuel in the hose has burned.
3. Unplug the power cord.

### RESTART AFTER SAFETY SHUTDOWN

1. Securely close valve at propane cylinder. Unplug heater.
2. Wait 5 minutes.
3. Restart following "Start" procedure.

### MAINTENANCE AND STORAGE

1. The heater should be inspected before each use, and at least annually by a qualified person.
2. Before each use, check the soft "O" ring seat at the bullnose of the POL fitting. If the "O" ring is cut, scuffed, or otherwise damaged, replace it with part number 6681.
3. Turn off the gas at the LP-gas supply cylinder(s) when the heater is not in use.
4. When the heater is to be stored indoors, the connection between the LP-gas supply cylinder(s) and the heater must be disconnected and the cylinder(s) removed from the heater and stored out of doors and in accordance with Chapter 5 of the standard for Storage and Handling of Liquefied Petroleum Gases ANSI/NFPA 58-1998.

## SERVICING

A hazardous condition may result if a heater is used that has been modified or is not functioning properly. When the heater is working properly:

- \* The flame is contained within the heater.
- \* The flame is essentially blue with perhaps some yellow tipping.
- \* There is no strong disagreeable odor, eye burning or other physical discomfort.
- \* There is no smoke or soot internal or external to the heater.
- \* There are no unplanned or unexplained shut downs of the heater.

The parts lists and wiring diagram show the heater as it was constructed. Do not use a heater which is different from that shown. In this regard, use only the hose, regulator and cylinder connection fitting (called a POL fitting) supplied with the heater. Do not use alternates. For this heater, the regulator must be set as shown on "specifications". If there is any uncertainty about the regulator setting, have it checked.

A heater which is *not* working right must be repaired, but *only* by a trained, experienced service person. Contact the factory for the service center closest to you, phone number (909) 981-5343.

You may also obtain in-warranty or out-of-warranty service by returning the product freight prepaid to:

**Scheu Products Company**  
 8855 Baker Avenue  
 Rancho Cucamonga, CA 91730

In-warranty products returned to the Service Department will be repaired with no charge for either parts or labor and will be returned to you freight prepaid. Please include a brief statement indicating date, place of purchase, the nature of the problem and proof of purchase.

Out-of-warranty products returned to the Service Department will be repaired with a charge for parts and labor and will be returned to you freight collect.

## SIZE AND CAPACITY OF PROPANE CYLINDERS REQUIRED

The charts below show the approximate size of the cylinder required for these heaters. To use the chart:

1. Select the lowest air temperature expected (at the bottom of the chart).
2. Move straight up to time of operation desired (left side of chart).
3. Read the cylinder size required.

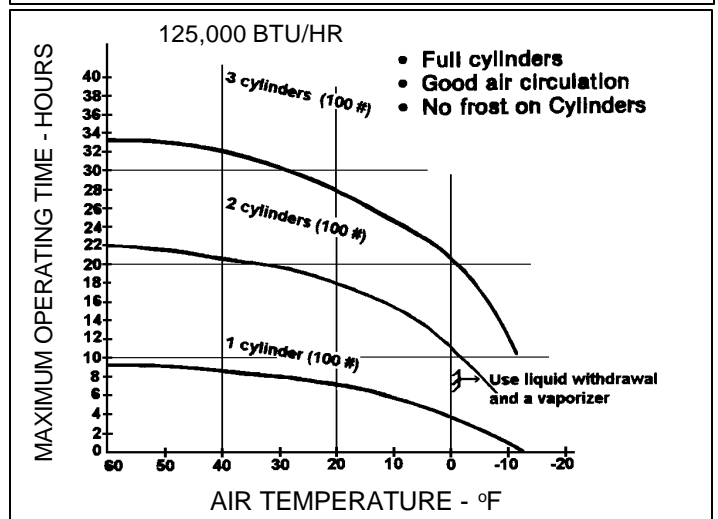
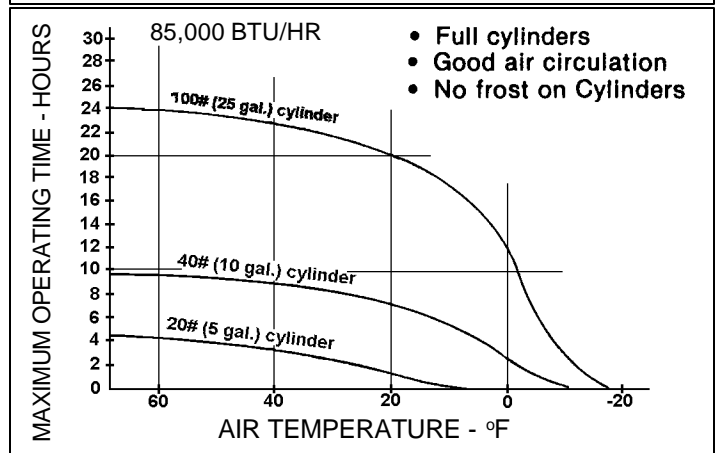
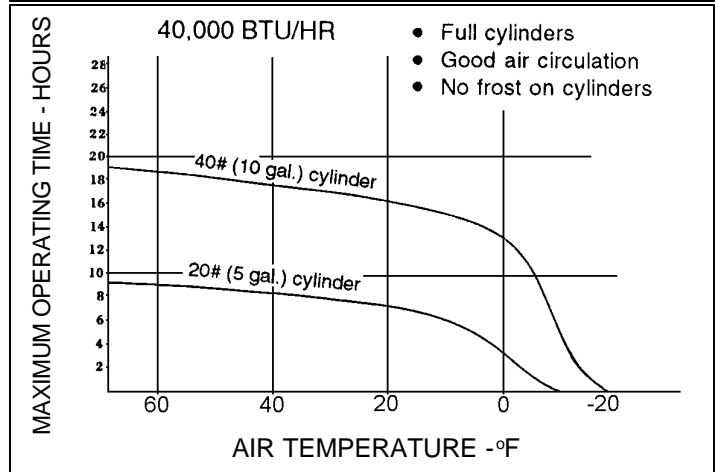
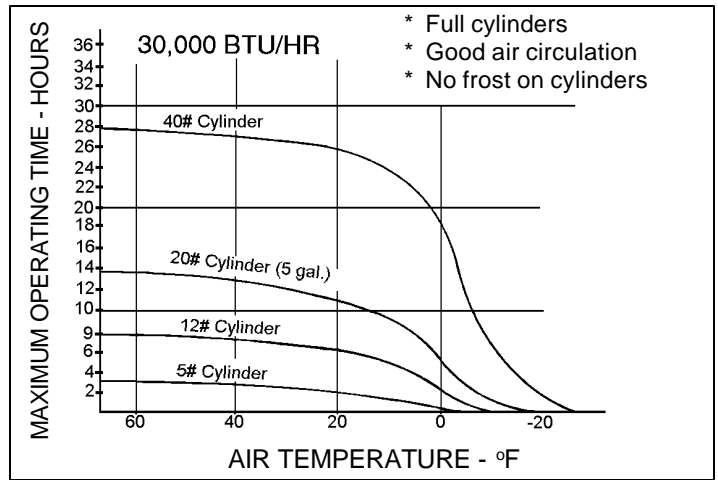

SPC-125/125-FAC

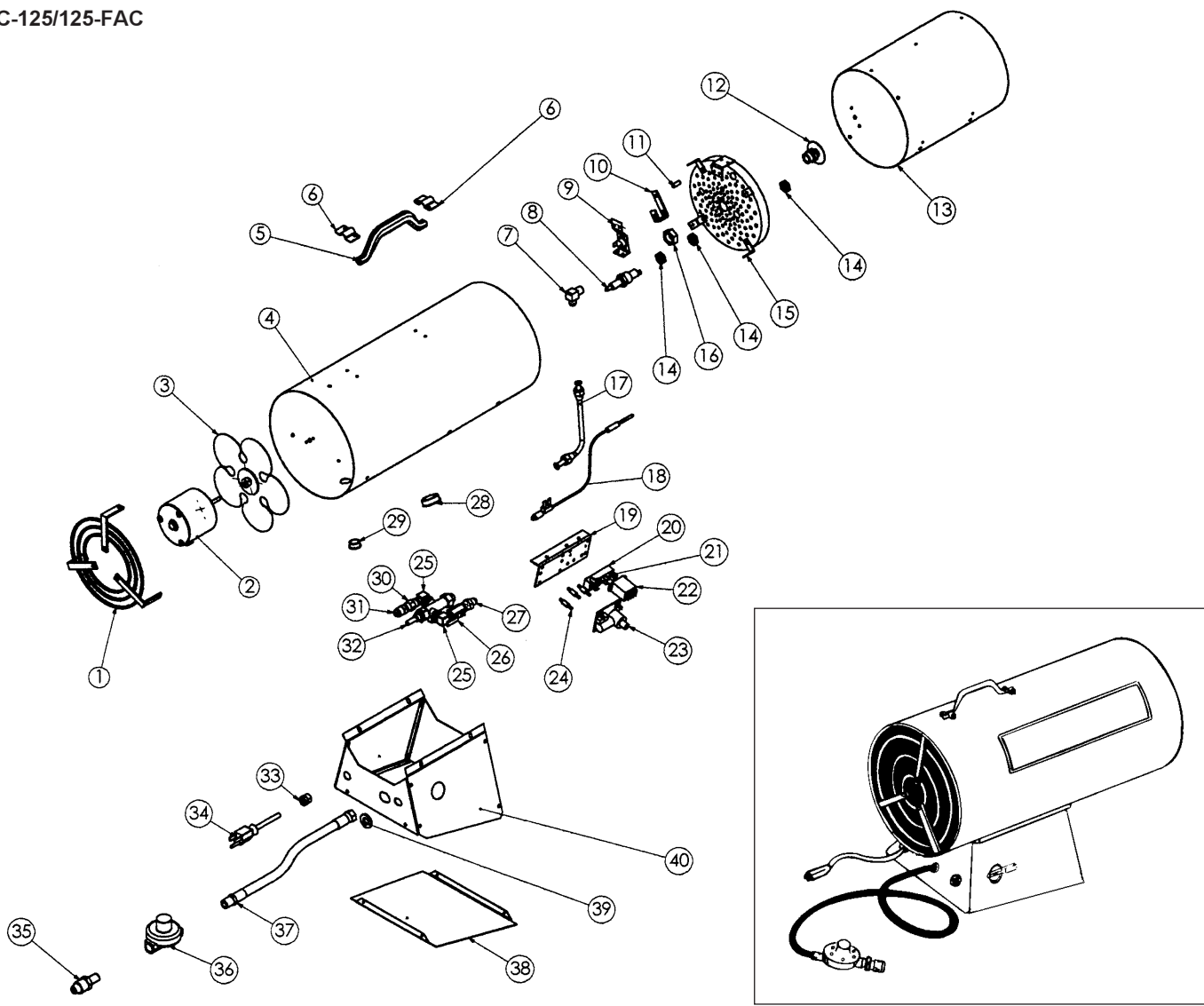

SPC-125 125-FAC					SPC-125 125-FAC				
Item	Part No.	Part No.	Description	Qty	Item	Part No.	Part No.	Description	Qty.
1	1671	1671	Grille Assembly	1	27	7405	7405	Fitting, Female Connector	1
2	1551	1551	Motor Assembly	1	28	6227	6227	Snap Bushing, 1 1/4 Nylon	1
3	7898	7898	Fan, 8"	1	29	7158	7158	Snap Bushing, 3/4 Nylon	1
4	1998	1999	Cylinder, Outer Shell Assembly	1	30	6133	6133	Fitting, Coupling	1
5	7095	7095	Handle	1	31	6127	6127	Fitting, Male Connector	1
6	7094	7094	Clip Handle Mounting	2	32	7285	7285	Valve, Thermoelectric	1
7	7433	7433	Fitting, Male Elbow	1	33	6223	6223	Bushing, Strain Relief	1
8	1083	1083	Spark Plug, 1/8 Gap	1	34	1036	1036	Power Cord	1
9	2003	2003	Control, High Limit Switch Assy.	1	35	6433	6433	POL Excess Flow 1/4 MPT	1
10	3036	3036	Bracket, Thermocouple	1	36	6257	6257	Regulator, 28" W.C.	1
11	3787	3787	Spacer, Thermocouple	1	37	6152	6152	Hose Assembly, LP	2
12	2002	2002	Orifice, LP Assembly	1	38	4019	4019	Bottom Control Box	1
13	2001	2001	Cylinder, Middle Assembly	1	39	7843	7843	Washer, Flat	1
14	3037	3037	Nut, Spark Plug	3	40	2005	2005	Control Box Assembly	1
15	2004	2004	Flame Holder Assembly	1	*	6374	6374	Label, Electrical Ground	1
16	3038	3038	Nut, Orifice Mounting	1	*	6752	6383	Label, Logo	2
17	1668	1668	Fuel Tube Assembly	1	*	7451	7451	Label, Operating Instructions	1
18	6654	6654	Thermocouple	1	*	7491	7491	Label, Ignition/Fuel	1
19	3044	3044	Bracket Ignition Relay	1	*	7716	7716	Label, Serial Number	1
20	6641	6641	Terminal Board	1	*	7903	7903	Label, BTU Rating	2
21	6065	6065	Spacer, Steel	1	*	7503	7503	Label, Wiring	1
22	1811	1811	Relay Assembly	1	*	7905	7905	Label, Model	1
23	3275	3275	Ignitor, Hi-Lo 801 Mini	1	*	7899	7899	Manual, Operating Instructions	1
24	6079	6079	Spacer, PC Standoff Nylon	3	*	1667	1667	Hose Regulator Assembly	1
25	6265	6265	Fitting, Elbow Street	2					
26	7897	7897	Ball Valve, Variable Rate	1					

## WIRING DIAGRAM

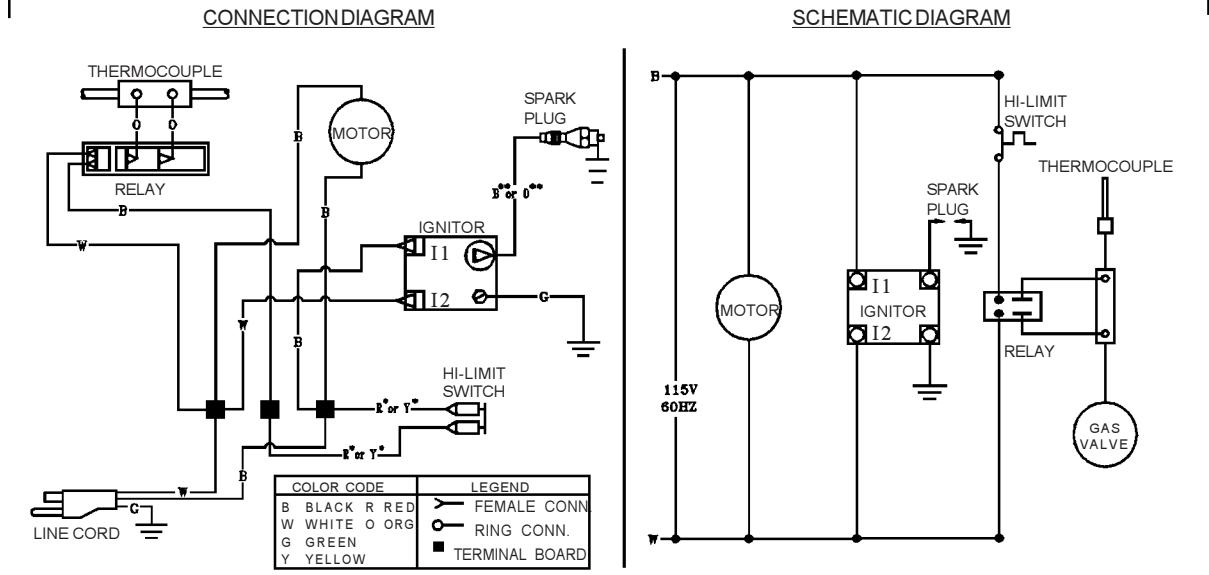

If any original wiring as supplied with the heater must be replaced, it must be replaced with type AWG 105° C wire or its equivalent except as indicated (\*\*type SP 2-200, \*\*SGI-250° C)

7503B

## WIRING CHART

PART NO.	COLOR	LENGTH	FROM	TO
1040	Black	6"	L (Ignitor)	T.B. Line
1070	Orange	11"	1 (Ignitor)	Spark Plug
1041	White	4 1/2"	N (Ignitor)	T.B. Return
1044	Yellow	16"	High Limit	T.B. Middle
1044	Yellow	16"	High Limit	T.B. Line
1441	Black	5"	Relay	T.B. Middle
1442	White	5"	Relay	T.B. Return
	Orange	6"	Relay	Thermocouple Junction Block
	Orange	6"	Relay	Thermocouple Junction Block

### INSTRUCTIONS FOR ORDERING PARTS

All parts orders must show heater Model No., Item No., Part No., and Description. We recommend that only parts supplied by the manufacturer be used on this unit. A locally purchased part may appear to be identical, although in reality it might endanger the heater or the persons operating the heater.

The heater should be serviced only by a trained, experienced service person.

Read the section on "Servicing" before ordering parts.

For parts order, call (909) 981-5343.