



TYPE MUH UNIT HEATER



FILE #E21609

- Unit mounts either horizontally or vertically. Totally versatile. For factories, warehouses, garages, stores, shipping rooms, power stations, aircraft hangers. Can be used for primary, supplementary, spot, or dual-system heating.
- Wide range of optional control kits are field installable, increasing the MUH adaptability to the specification market.
- Forced air unit heater with 10 power ratings; from 3KW to 50 KW heating output; 208, 240, 277 and 480V, 10,230 to 170,500 BTU/hr.
- 32 compatible models (no need to try to assemble a heating system from 70 or 80 models!)
- Heavy gauge die-formed steel housing. Two-toned, smartly styled.
- Advanced pull-through air flow design draws air across heating element for more even air distribution and cooler element operation.
- Specially designed venturi outlet to meet that added throw as required in vertical position.
- Branch circuit fusing (when required).
- Completely enclosed fan motor.
- 1- or 3-phase wiring on 5 through 10 KW 208/240V and 15 KW 208V units (field interchangeable).
- Aluminum-finned, copper clad steel sheath heating element has longer useful life, because of cooler sheath temperature and faster heat dissipation.
- 24V control transformer standard on most models, providing a safer and more accurate means of temperature control. 3KW and 5KW, 208-277V, have line voltage controls as standard (24V control available on made-to-order basis).
- Automatic reset linear thermal cut-out, capillary type, provides protection over entire length of element areas (Manual reset protection available on made-to-order basis).
- 2-speed fan selector switch (25 to 50 KW models).
- Fan delay feature eliminates cold drafts. Element heats up before fan cuts in, then fan continues to distribute heat after element shuts off.
- Ruggedly built, yet lighter weight for easier installation. No piping flues, valves, or traps.
- Individually adjustable discharge louvers to control air flow.
- Choice of optional diffusers for variety of air patterns, maximizing heat concentration and coverage in the vertical position.
- Meets all UL, NEC, and OSHA requirements.



SELECTION CHART

CAT. NO.	VOLTS	ELECTRICAL DATA				CONTROL VOLT (1)	2 STAGE ELEMENT CONTROL	AIR DELIVERY DATA			FAN MOTOR DATA			MAXIMUM EFFECTIVE MOUNTING HEIGHT		HORI. AIR THROW	WIRE SIZE	INSTALLED WEIGHT (LBS.) W/BRACK.
		PHASE	KW	BTU/HR.	AMPS (3)			CFM(2)	FPM(2)	ΔT(°F)	VOLTS	RPM(2)	HP	HORIZ.	VERT.			
MUH-03-81	208	1Ø	3.0	10.2	14.5	208	N/A	350	800	27 °	208	1600	1/100	8	9	12	AWG 12	27
MUH-03-21	208/240	1Ø	2.2/3.0	7.5/10.2	11.0/14.5	208/240	N/A	350	800	27 °	208/240	1600	1/100	8	9	12	AWG 12	27
MUH-03-71	277	1Ø	3.0	10.2	14.5	277	N/A	350	800	27 °	277	1600	1/100	8	9	12	AWG 14	27
MUH-03-31	347	1Ø	3.0	10.2	14.5	347	N/A	350	800	27 °	347	1600	1/100	8	9	12	AWG 14	27
MUH-03-41	480	3Ø	3.0	10.2	14.5	24	N/A	350	800	27 °	480	1600	1/100	8	9	12	AWG 14	27
MUH-03-61	600	1Ø	3.0	10.2	14.5	600	N/A	350	800	27 °	600	1600	1/100	8	9	12	AWG 14	27
MUH-05-81	208	1-3Ø	5.0	17.0	24.0	208	5A	350	800	45 °	208	1600	1/100	8	9	12	AWG 10	27
MUH-05-21	208/240	1-3Ø	3.75/5.0	12.6/17.0	18.0/21.0	208/240	5A	350	800	45 °	208/240	1600	1/100	8	9	12	AWG 10	27
MUH-05-71	277	1Ø	5.0	17.0	18.0	277	N/A	350	800	45 °	277	1600	1/100	8	9	12	AWG 10	27
MUH-05-31	347	1Ø	5.0	17.0	18.0	347	N/A	350	800	45 °	347	1600	1/100	8	9	12	AWG 10	27
MUH-05-41	480	3Ø	5.0	17.0	18.0	24	N/A	350	800	45 °	480	1600	1/100	8	9	12	AWG 14	27
MUH-05-61	600	1Ø	5.0	17.0	18.0	600	N/A	350	800	45 °	600	1600	1/100	8	9	12	AWG 10	27
MUH-07-81	208	1-3Ø	7.5	25.6	36.0	24	5B	650	970	37 °	208	1600	1/30	9	14	18	AWG 6	38
MUH-07-21	208/240	1-3Ø	5.6/7.5	19.1/25.6	27.0/31.3	24	5B	650	970	37 °	208/240	1600	1/30	9	14	18	AWG 8	38
MUH-07-71	277	1Ø	7.5	25.6	27.0	24	5B	650	970	37 °	277	1600	1/30	9	14	18	AWG 8	38
MUH-07-31	347	1Ø	7.5	25.6	21.6	24	5B	650	970	37 °	347	1600	1/30	9	14	18	AWG 14	38
MUH-07-41	480	3Ø	7.5	25.6	9.0	24	5B	650	970	37 °	480	1600	1/30	9	14	18	AWG 14	38
MUH-07-61	600	1Ø	7.5	25.6	7.3	24	5B	650	970	37 °	600	1600	1/30	9	14	18	AWG 14	38
MUH-10-81	208	1-3Ø	10.0	34.1	48.0	24	5B	650	970	49 °	208	1600	1/30	9	14	18	AWG 4	38
MUH-10-21	208/240	1-3Ø	7.5/10.0	25.6/34.1	36.0/48.0	24	5B	650	970	49 °	208/240	1600	1/30	9	14	18	AWG 6	38
MUH-10-71	277	1Ø	10.0	34.1	36.0	24	5B	650	970	49 °	277	1600	1/30	9	14	18	AWG 6	38
MUH-10-31	347	1Ø	10.0	34.1	28.8	24	5B	650	970	49 °	347	1600	1/30	9	14	18	AWG 14	38
MUH-10-41	480	3Ø	10.0	34.1	12.0	24	5B	650	970	49 °	480	1600	1/30	9	14	18	AWG 14	38
MUH-10-61	600	1Ø	10.0	34.1	9.7	24	5B	650	970	49 °	600	1600	1/30	9	14	18	AWG 14	38
MUH-15-81	208	1-3Ø	15.0	51.2	72.0	24	5A	910	1640	52 °	208	1530	1/20	11	20	35	AWG 2	53
MUH-15-21	208/240	3Ø	11.2/15.0	38.2/51.2	31.3/36.1	24	5C	910	1640	52 °	208/240	1530	1/20	11	20	35	AWG 6	53
MUH-15-41	480	3Ø	15.0	51.2	18.0	24	5C	910	1640	52 °	480	1530	1/20	11	20	35	AWG 10	53
MUH-15-61	600	1Ø	15.0	51.2	14.5	24	5C	910	1640	52 °	600	1530	1/20	11	20	35	AWG 12	53
MUH-20-81	208	3Ø	20.0	68.2	56.0	24	5A	1320	2060	48 °	208	1500	1/10	12	23	41	AWG 4	60
MUH-20-21	208/240	3Ø	15.0/20.0	51.2/68.2	41.2/48.0	24	5C	1320	2060	48 °	208/240	1500	1/10	12	23	41	AWG 4	60
MUH-20-41	480	3Ø	20.0	68.2	24.0	24	5C	1320	2060	48 °	480	1500	1/10	12	23	41	AWG 10	60
MUH-20-61	600	3Ø	20.0	68.2	19.3	24	5C	1320	2060	48 °	600	1500	1/10	12	23	41	AWG 12	60
MUH-25-21	208/240	3Ø	18.7/25.0	63.8/85.2	52.0/60.0	24	5A	2100/1800	2100/2030	38 °/44 °	208/240	1600/1375	1/4	13	23	50	AWG 3	93
MUH-25-41	480	3Ø	25.0	85.2	30.0	24	5C	2100/1800	2100/2030	38 °/44 °	480	1600/1375	1/4	13	23	50	AWG 8	93
MUH-25-61	600	3Ø	25.0	85.2	24.2	24	5C	2100/1800	2100/2030	38 °/44 °	600	1600/1375	1/4	13	23	50	AWG 10	93
MUH-30-81	208	3Ø	30.0	102.3	84.0	24	5A	2100/1800	2100/2030	45 °/53 °	208	1600/1375	1/4	12	20	50	AWG 1	93
MUH-30-21	208/240	3Ø	22.5/30.0	76.7/102.3	63.0/72.3	24	5A	2100/1800	2100/2030	45 °/53 °	208/240	1600/1375	1/4	12	20	50	AWG 2	93
MUH-30-41	480	3Ø	30.0	102.3	36.0	24	5C	2100/1800	2100/2030	45 °/53 °	480	1600/1375	1/4	12	20	50	AWG 6	93
MUH-30-61	600	3Ø	30.0	102.3	29.0	24	5C	2100/1800	2100/2030	45 °/53 °	600	1600/1375	1/4	12	20	50	AWG 8	93
MUH-40-21	208/240	3Ø	30.0/40.0	102.3/136.4	83.4/96.4	24	5A	3000/2600	3260/2900	42 °/49 °	208/240	1525/1420	1/2	15	28	60	AWG 1/0	114
MUH-40-41	480	3Ø	40.0	136.4	48.0	24	5A	3000/2600	3260/2900	42 °/49 °	480	1525/1420	1/2	15	28	60	AWG 4	114
MUH-40-61	600	3Ø	40.0	136.4	38.7	24	5A	3000/2600	3260/2900	42 °/49 °	600	1525/1420	1/2	15	28	60	AWG 6	114
MUH-50-81	208	3Ø	50.0	170.5	139.0	24	5A	3000/2600	3260/2900	53 °/61 °	208	1525/1420	1/2	15	25	60	AWG 4/0	114
MUH-50-21	208/240	3Ø	37.5/50.0	127.3/170.5	104.2/120.4	24	5A	3000/2600	3260/2900	53 °/61 °	208/240	1525/1420	1/2	15	25	60	AWG 3/0	114
MUH-50-41	480	3Ø	50.0	170.5	60.2	24	5A	3000/2600	3260/2900	53 °/61 °	480	1525/1420	1/2	15	25	60	AWG 4	114
MUH-50-61	600	3Ø	50.0	170.5	48.3	24	5A	3000/2600	3260/2900	53 °/61 °	600	1525/1420	1/2	15	25	60	AWG 3	114

Note:

1. All standard units are supplied with a low voltage control transformer and contactor (24V) except MUH-03 & 05, 208, 240 & 277 volt models. Low voltage control on these units are available on made to order. All units are also available on special order for 120 volt control; internal and transformer or external without transformer.
2. On dual voltage units; CFM, FPM, and RPM are shown at higher voltage.
3. On dual phase units, maximum amp draw is listed for respective voltage.
4. 25 thru 50 KW models have two speed motors and dual CFM ratings.

5A. Standard.

5B. Optional - made to order - amp load unbalanced on 3 Phase.

5C. Optional - made to order - amp load balanced on 3 Phase.

ACCESSORIES

CATALOG #	DESCRIPTION	ELECTRICAL RATING	USE WITH HEATER NO.
MT-1	Single Pole Internal Thermostat Temp. Range: 40°F - 85°F	25A; 120, 240V. A.C. Res. 22A; 277V.A.C. Res.	All MUH Series Heaters (except MUH05-21 3Ø and mUH025-81 3Ø, which use MT-2).
MT-2	Two Stage Internal Thermostat Temp. Range: 40°F - 85°F	25A; 120, 240V. A.C. Res. 22A; 277V.A.C. Res. 125V.A; Pilot Duty	MUH05-21 3Ø, MUH05-81 3Ø, MUH-15-8, MUH-20-8, MUH-25-2, MUH-30-2, MUH-30-8, MUH-40-2, MUH-50-2, MUH-50-4, MUH-50-8
MCFS	Internal Summer Fan Switch	6A; 600V.A.C. Res. 2 HP; 250, 480, 600V.A.C. 1, 2, or 3Ø	All MUH Series Heaters
MRFS-1	Remote Summer Fan Switch (Line Voltage)	2 HP; 250-480V.A.C.	All MUH Series Heaters
NRFS-2	Remote Summer Fan Switch with Relay (24V Coil-Single Pole Normally Open)	6 AFL, 35 ALR, 250V.A.C. 60 Hz 3 AFL, 18 ALR, 480V.A.C. 60 Hz	All MUH Series Heaters (except MUH03-21, MUH03-71, MUH03-81, MUH05-21, MUH05-71, MUH05-81 Units, unless optional control transformer is supplied.
MHRT	Heater Recovery Thermostat with Relay (24V Coil-Single Pole Normally Open) Hi — 120°F; Low — 60°F	6 AFL, 35 ALR, 250V.A.C. 60 Hz 3 AFL, 18 ALR, 480V.A.C. 60 Hz	All MUH Series Heaters (except MUH03-21, MUH03-71, MUH03-81, MUH05-21, MUH05-71, MUH05-81 Units, unless optional control transformer is supplied.
MPDS-25	Power Disconnect Switch (3 Pole)	25A, 600V.A.C. Res.	MUH03-21, MUH03-41, MUH03-71, MUH03-81, MUH05-21, MUH05-41, MUH05-71, MUH05-81, MUH-07-4, MUH-10-4, MUH-15-4, MUH-20-4
MPDS-60	Power Disconnect Switch (3 Pole)	63A, 600V.A.C. Res.	MUH-07-02, MUH-07-7, MUH-07-8, MUH-10-2, MUH-10-7, MUH-10-8, MUH-15-2 MUH-15-8 3Ø only, MUH-20-2, MUH-20-8, MUH-25-2, MUH-25-4, MUH-30-4 MUH-40-4, MUH-50-4

UNIVERSAL WALL & CEILING BRACKET

CATALOG NO.	USED ON
MMB-10	MUH-03, 05, 07 & 10
MMB-20	MUH-15 & 20
MMB-30	MUH-25 & 30
MMB-50	MUH-40 & 50

CEILING BRACKET

CATALOG NO.	USED ON
MCMB-10	MUH-03, 05, 07 & 10
MCMB-20	MUH-15 & 20
MCMB-30	MUH-25 & 30
MCMB-50	MUH-40 & 50

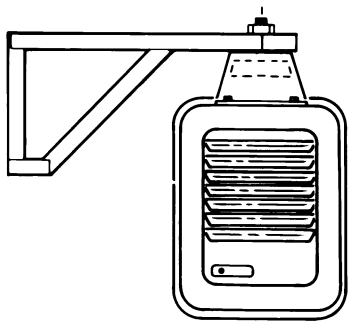

BRACKET SIZE

DIMENSION	3 - 20Kw	25 - 50Kw
A	7 ¹ / ₄ "	9 ⁷ / ₁₆ "
B	9 ¹ / ₂ "	14 ³ / ₈ "
C	7 ¹ / ₄ "	12 ¹ / ₈ "
D	1 ¹⁵ / ₁₆ "	2 ¹ / ₁₆ "
E	2 ¹ / ₄ "	3"
L	20 ¹ / ₂ "	28 ¹⁵ / ₁₆ "
M	9 ¹⁵ / ₁₆ "	14 ¹⁵ / ₁₆ "
N	3 ¹ / ₄ "	4 ¹ / ₂ "

OPTIONAL VERTICAL CEILING MOUNTING BRACKET

CATALOG NUMBER	USED ON	STANDARD CARTON QTY.	WT. LBS.
MVDMB5	MUH03-05	1	5
MVDMB20	MUH07-20	1	7
MVDMB50	MUH25-50	1	9

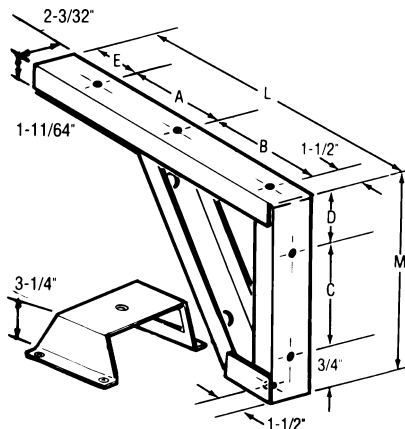

OPTIONAL BUILT-IN CONTROLS AND ACCESSORIES ON MUH HEATERS

FACTORY INSTALLED ONLY††	DESCRIPTION
	MUH-03 & 05 (208, 208/240, 277V Supply) 24 or 120V Control Transformer and Power Contactor 24 or 120V H.C. Power Contactor
	MUH-03 & 05 (480V Supply) & MUH-07 thru MUH-50, Optional 120V Control
	2-Stage Control of Elements (See Note 5)
	Manual Reset.
	Outlet Mesh (Bird Screen) For all MUH Heaters

††Optional built-in controls and accessories factory installed only - Not to be field installed

DIMENSIONS

CAT. NO.	HEIGHT	WIDTH	DEPTH
MUH-03 & 05	16"	14"	7 ¹ / ₂ "
MUH-07 & 10	21 ³ / ₄ "	19"	7 ¹ / ₂ "
MUH-15 & 20	21 ³ / ₄ "	19"	12 ³ / ₄ "
MUH-25 & 30	30"	26 ⁵ / ₈ "	11 ³ / ₄ "
MUH-40 & 50	30"	26 ⁵ / ₈ "	17 ¹ / ₈ "

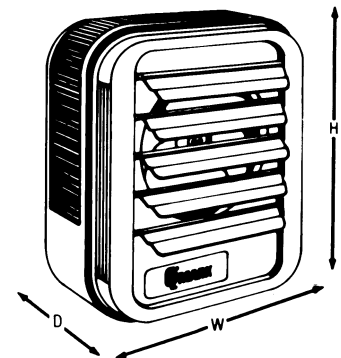

MOUNTING LIMITATIONS

Unit heaters should not be used in potentially explosive atmospheres. The finish is not intended for direct salt spray exposure in marine applications or the highly corrosive atmospheres of swimming pools, chemical storage bins, etc. Do not install unit heaters above recommended maximum mounting height. Obstructions must not block unit heater air inlet or discharge. Heaters must be mounted at least 7' above the floor to prevent accidental contact with the heating element or fan blade which could cause injury.

DIFFUSER SELECTOR TABLES FOR VERTICAL MOUNTING

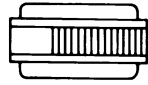
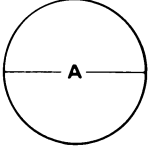
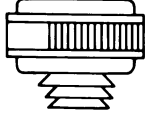
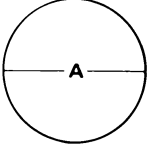
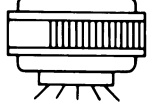
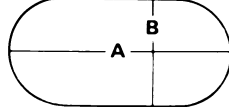
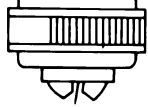
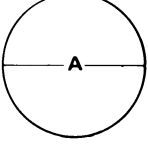
CATALOG NO.	DESCRIPTION	CATALOG NO.	MAX. MNT. HT.	A DIMENSION	DIFFUSER PATTERN AND AREA
NONE NONE	WITHOUT DIFFUSER	MUH-03 & MUH-05 MUH-07 & MUH-10	9 14	18 26	 
NONE NONE	No diffuser needed where a straight downflow air pattern is required. For maximum air throw, remove louvers. Any of three diffusers can be added to basic heater.	MUH-15	20	35	
NONE NONE		MUH-20	23	40	
NONE NONE		MUH-25	23	63	
NONE NONE		MUH-30	20	55	
NONE NONE		MUH-40 MUH-50	28 25	70 63	
MAD-S MAD-M	ANEMOSTAT DIFFUSER The "comfort" diffuser. Produces draft-free air movement at low mounting heights. Floor coverage shown in table.	MUH-03 & MUH-05 MUH-07 & MUH-10	8 12	18 28	 
MAD-M MAD-M		MUH-15	15	35	
MAD-M MAD-M		MUH-20	17	40	
MAD-L MAD-L		MUH-25	19	60	
MAD-L MAD-L		MUH-30	17	55	
MAD-L MAD-L		MUH-40 MUH-50	22 20	77 70	
MLD-S MLD-M	LOUVER DIFFUSER Permits directional (straight line) air flow as in air curtain application over doorways. Rectangular coverage. Louvers can be turned in either direction.	MUH-03 & MUH-05 MUH-07 & MUH-10	9 14	25(A) 12(B) 39(A) 19(B)	 
MLD-M MLD-M		MUH-15	18	50(A) 25(B)	
MLD-M MLD-M		MUH-20	20	56(A) 28(B)	
MLD-L MLD-L		MUH-25	23	72(A) 36(B)	
MLD-L MLD-L		MUH-30	20	80(A) 40(B)	
MLD-L MLD-L		MUH-40 MUH-50	24 22	88(A) 44(B) 80(A) 40(B)	
MRD-S MRD-M	RADIAL DIFFUSER Increases floor coverage. Adjustable fins, in vertical mode, direct downward in a tight pattern. Conversely, when fins are tilted to 45° angle, floor coverage is up to 25% greater at relatively low mounting heights.	MUH-03 & MUH-05 MUH-07 & MUH-10	9 14	20 31	 
MRD-M MRD-M		MUH-15	18	40	
MRD-M MRD-M		MUH-20	20	45	
MRD-L MRD-L		MUH-25	23	69	
MRD-L MRD-L		MUH-30	20	60	
MRD-L MRD-L		MUH-40 MUH-50	24 22	75 68	

TYPE MUH-35 UNIT HEATER



FILE #E21609

- Mounts either on the wall or from the ceiling can be used for primary or spot heating. For factories, garages, schools, etc.
- Airflow can be directed horizontally, vertically or any position between for precise control.
- Multiple wattage heat selector switch. Either 5KW or 3.3KW @ 240V (3.7KW or 2.5KW @ 208V) for just the right amount of heat.
- Fan only switch allows fan to cycle automatically with elements or run continuously for air movement when no heat is required.
- Built-in bi-metal thermostat. Range 40° to 90°F.
- Heater is shipped with ceiling/wall bracket.
- Heavy gauge die-formed steel housing.
- Advanced pull-through air flow design draws air across heating element for more even air distribution and cooler element operation.
- Specially designed venturi outlet to meet that added throw as required in vertical position.
- Completely enclosed fan motor.
- Aluminum-finned, copper clad steel sheath heating element has longer useful life, because of cooler sheath temperature and faster heat dissipation.
- Automatic reset linear thermal cut-out capillary type, provides protection over entire length of element area.
- Ruggedly built, yet lighter weight for easier installation. No piping flues, valves, or traps.
- Meets all UL, NEC, and OSHA requirements.



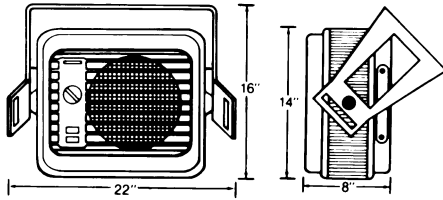

SELECTION CHART

CATALOG NUMBER	ELECTRICAL DATA						2 STAGE ELEMENT CONTROL	AIR DELIVERY DATA			FAN MOTOR DATA			MAXIMUM EFFECTIVE MOUNTING HEIGHT		HORIZ. AIR THROW	WIRE SIZE	INSTALLED WEIGHT (lbs) W/ BRACKET
	VOLTS	PHASE	KW	BTU/HR (000)	AMPS	CONTROL VOLTAGE		CFM	FPM	$\Delta T(^{\circ}F)$	VOLTS	RPM	HP	HORIZ.	VERT.			
MUH-35	240/208	1	5.0/3.7	17.0/12.6	21.0/18.0	17.0/12.6	MUH-35	210	550	71°	240/208	1600	1/100	8	51	24	AWG 10	22

ARCHITECT'S AND ENGINEER'S SPECIFICATIONS*

- Unit mounts either horizontally or vertically. Totally versatile. For factories, warehouses, garages, stores, shipping rooms, power stations, aircraft hangers. Can be used for primary, supplementary, spot, or dual-system heating.
- Wide range of optional control kits are field installable, increasing the MUH adaptability to the specification market.
- Forced air unit heater with 10 power ratings; from 3KW to 50 KW heating output; 208, 240, 277 and 480V, 10,230 to 170,500 BTU/hr.
- 32 compatible models (no need to try to assemble a heating system from 70 or 80 models!)
- Heavy gauge die-formed steel housing. Two-toned, smartly styled.
- Advanced pull-through air flow design draws air across heating element for more even air distribution and cooler element operation.
- Specially designed venturi outlet to meet that added throw as required in vertical position.
- Branch circuit fusing (when required).
- Completely enclosed fan motor.
- 1- or 3-phase wiring on 5 through 10 KW 208/240V and 15 KW 208V units (field interchangeable).
- Aluminum-finned, copper clad steel sheath heating element has longer useful life, because of cooler sheath temperature and faster heat dissipation.
- 24V control transformer standard on most models, providing a safer and more accurate means of temperature control. 3KW and 5KW, 208-277V, have line voltage controls as standard (24V control available on made-to-order basis).
- Automatic reset linear thermal cut-out, capillary type, provides protection over entire length of element areas (Manual reset protection available on made-to-order basis).
- 2-speed fan selector switch (25 to 50 KW models).
- Fan delay feature eliminates cold drafts. Element heats up before fan cuts in, then fan continues to distribute heat after element shuts off.
- Ruggedly built, yet lighter weight for easier installation. No piping flues, valves, or traps.
- Individually adjustable discharge louvers to control air flow.
- Choice of optional diffusers for variety of air patterns, maximizing heat concentration and coverage in the vertical position.
- Meets all UL, NEC, and OSHA requirements.

*QMark reserves the right to make changes without prior notice.



A Division of Marley Engineered Products

470 Beauty Spot Road East
Bennettville, SC 29512